

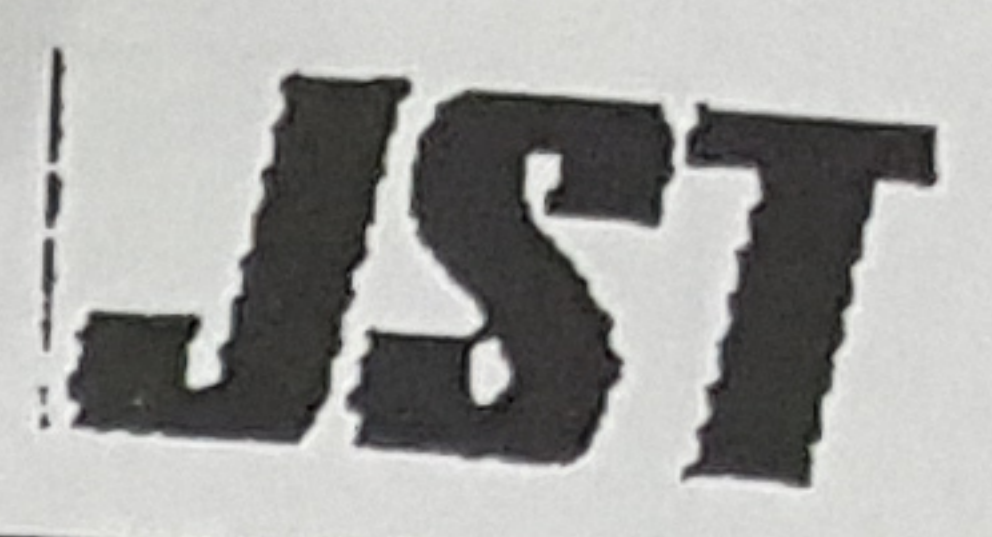

CMKS-L DIES CONSTRUCTION SHEET



Terminal/Contact Model No.	SXAM-001T-P0.6	Die set Model No.	SXAM/XA-001-06
	SXA-001T-P0.6	Applicator Model No.	CMKS-L
		Crimp shape (wire)	N-1.4
		Crimp shape (ins)	N-1.8

Clearance between Crimper (B) and Shear blade : 0.1

Description	No.	Description	No.
Crimper (A)	63165	Crimper anvil (A)	C75298
Crimper (B)	64565	Crimper anvil (B)	C76660
Spacer (A)	65120	Tongue hold punch spring	87110
Spacer (B)			
Spacer (C)			
Punch		Hex. socket head bolt	M5x15
Die holder	68225	Spacer	C77475
Spring	67530	Shear blade	C74370
Wire block		Shear blade supporter	C73120
Insulation block	A325	Shear blade base	C78010
Wire hold punch	B264	Shear blade spring	C87010
Wire hold punch spring	68235	Hex. nut	M5
	87270	Feed finger	G6190
		Feed finger holder	G6180
Guide plate (L)	C81510	Stripper	
Guide plate (R)	C82647	Stripper bracket	91235
Feed plate	C84310	Stripper pin	
Pressure plate	C83170		
Pressure spring(2pcs)	87001	Scrap cover	C95310
Tongue hold punch	68265		
Tongue hold punch holder	68515		

Wire and Crimp height			
Wire		Crimp height (mm)	
Type	Size	Wire	Ins
UL1007	#28	0.57~0.62	1.7
UL1007	#26	0.65±0.05	1.7
UL1007	#24	0.70±0.05	1.8
UL1007	#22	0.75±0.05	1.9

Remarks

JST

Side-Feeding Applicator
CMKS-L
Die Set Assembly

No. CP-CS851

Die Set Model No. SXAM/XA-001-06

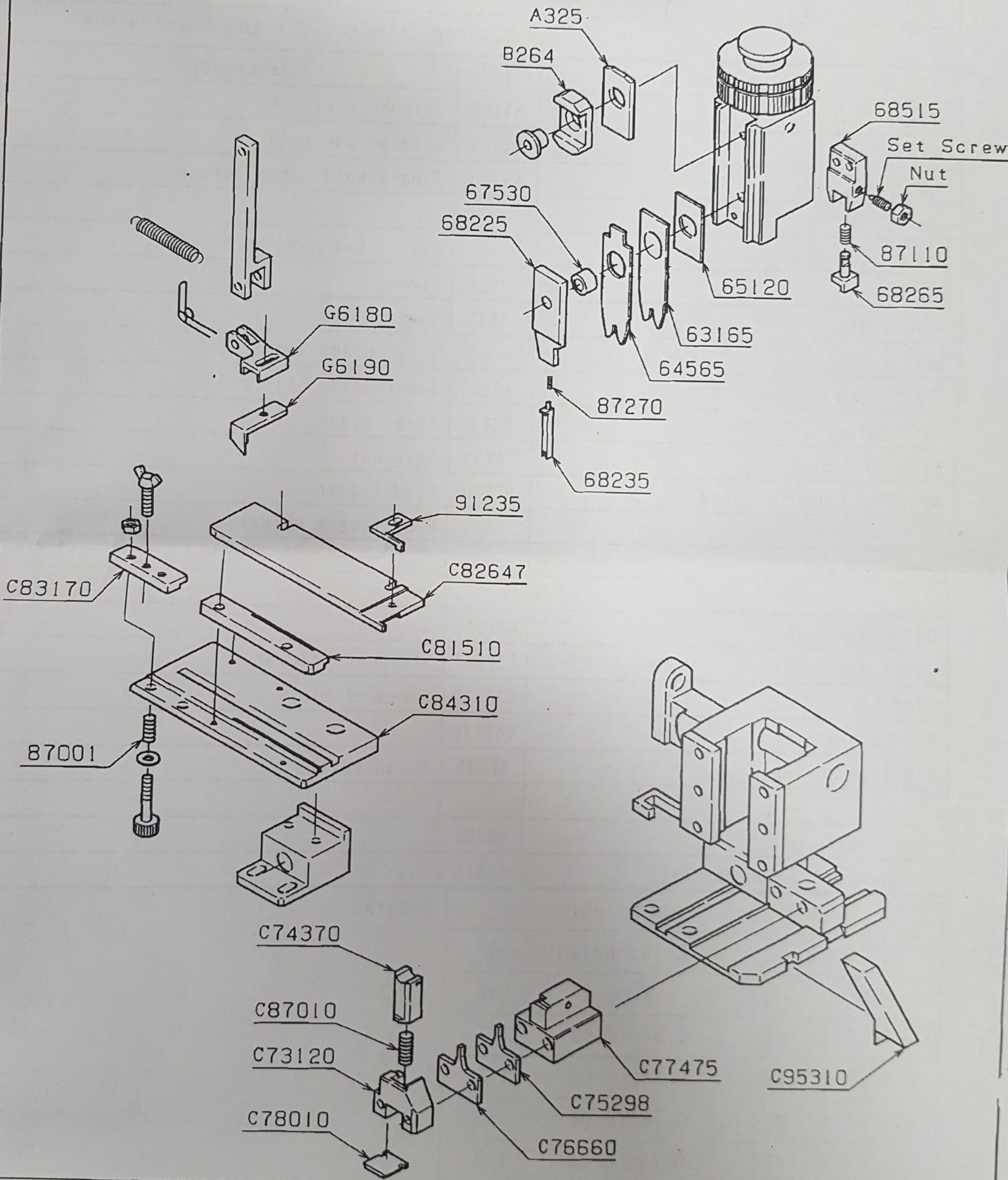

Date	Drawn by
AUG.28.'03	K.FUJII