

# MKS-L DIES CONSTRUCTION SHEET



**JST**

Terminal/Contact Model No.	SHF-001T-0.8SS	Die set Model No.	SHF-001-08S
	SHF-001T-0.8BS	Applicator Model No.	MKS-L, MKS-LS
		Crimp shape (wire)	N-1.5
		Crimp shape (ins)	N-1.8

Clearance between Crimper (B) and Shear blade 0.1

Description	No.	Description	No.
Crimper (A)	63291	Crimper anvil (A)	75361
Crimper (B)	64190	Crimper anvil (B)	76270
Spacer (A)			
Spacer (B)			
Spacer (C)			
Punch			
Die holder	68042	Spacer	77121
Spring		Shear blade	74030
Wire block	387	Shear blade supporter	73030
Insulation block	326	Shear blade base	78010
		Shear blade spring	87010
		Feed finger	86020
		Feed finger holder	86040
Guide plate (L)	81160	Stripper	91380
Guide plate (R)	82160	Stripper bracket	92233
Feed plate	84100	Stripper pin	
Pressure plate	83020		
Pressure spring (2pcs)	87001	Scrap cover	95151

**Wire and Crimp height**

Wire		Crimp height (mm)	
Type	Size	Wire	Ins
UL1007	#28	0.65~0.70	1.6
UL1007	#26	0.70±0.05	1.7
UL1007	#24	0.75±0.05	1.7
UL1007	#22	0.80±0.05	1.8

Remarks

Prepared by	<i>H. Fujii</i>	Issue date	Apr 15, 1996
Checked by	<i>/</i>	No.	CP-MS075

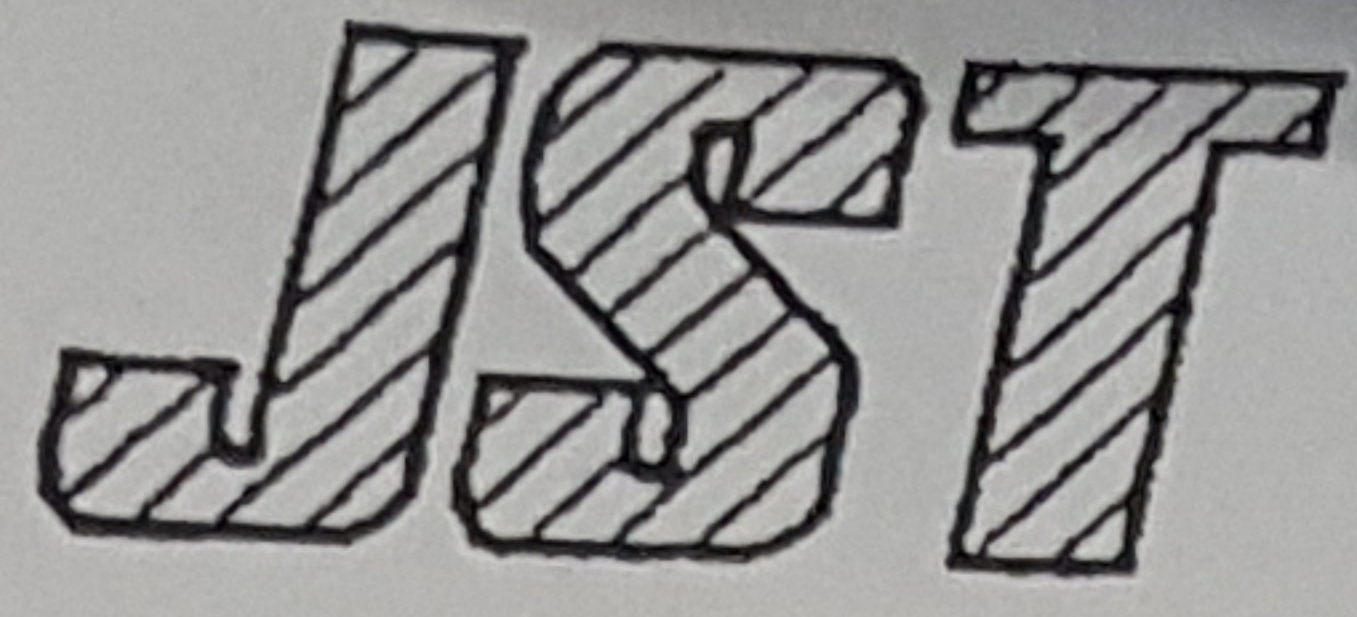

Side-Feeding Applicator  
MKS-L  
Die Set Assembly

Applicable terminal/  
contact

- SHF-001-0.8S
- 0.8BS
- 0.8CS
- 0.8SS

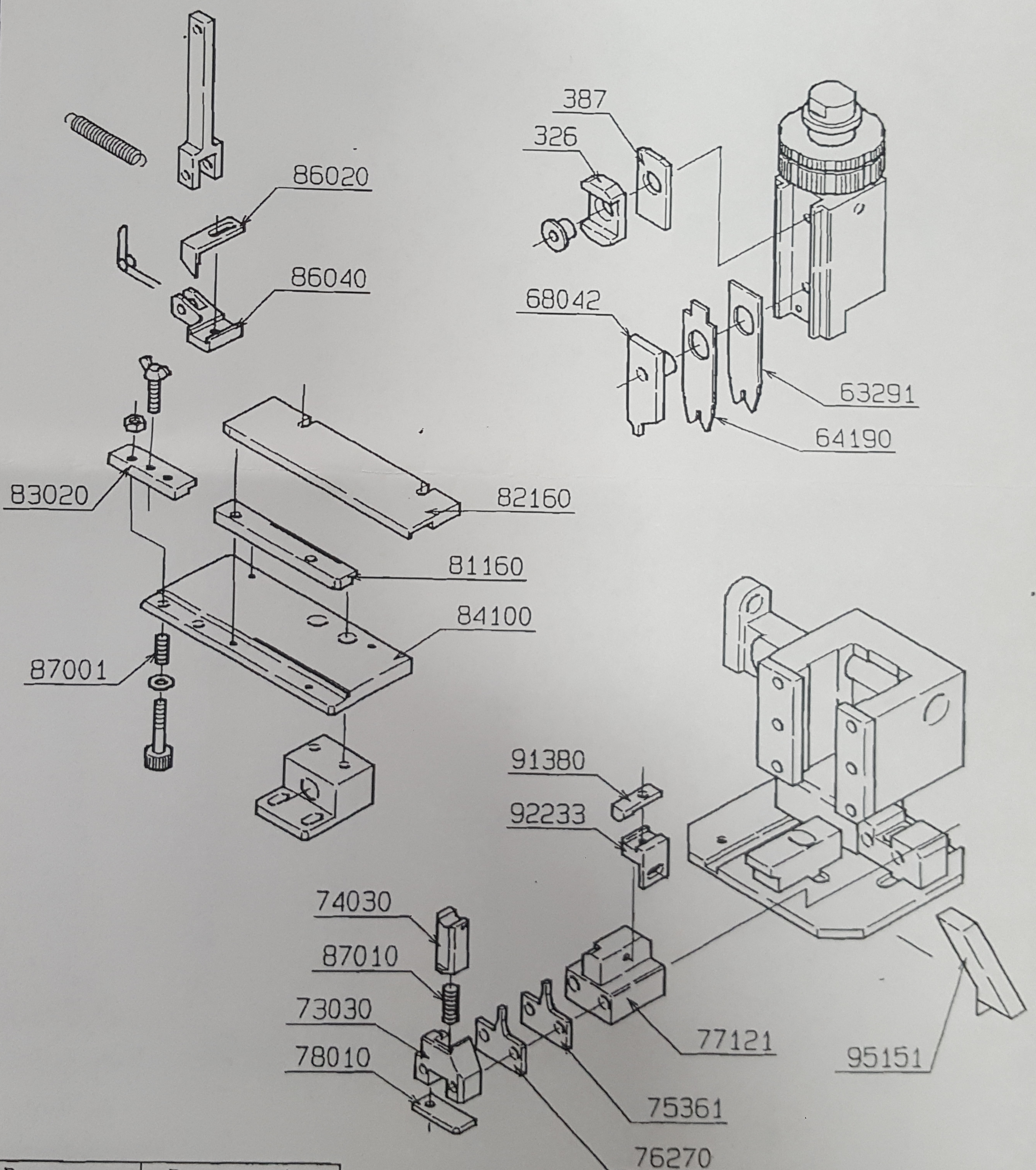

Date	Drawn by
Dec. 18. 1990	J. Onishi

(CP-MS075)